

## **FX3U-48MR6AD2DA PLC Programmable Logic Controller 24DI 24DO 6AI 2AO**

The FX3U-48MR6AD2DA PLC is a programmable logic controller designed for industrial automation systems requiring digital and analog signal control.

### **Product Overview**

The FX3U-48MR6AD2DA PLC provides 24 digital inputs, 24 relay outputs, 6 analog inputs, and 2 analog outputs, offering flexible control for various automation tasks. It supports high-speed inputs, real-time clock functionality, and compatibility with Mitsubishi GX-Developer and GX-WORK2 software, making it suitable for integration into existing control systems.

This PLC is equipped with an industrial-grade 32-bit MCU to support stable and efficient operation in demanding environments.

### **Key Features & Advantages**

- 24 digital input channels for reliable signal acquisition
- 24 relay outputs (Y0–Y27, 5A) for controlling AC contactors, intermediate relays, and electromagnetic devices
- 6 analog inputs: 3 channels (0–10V) and 3 channels (0–20mA)
- 2 analog outputs (0–10V) for analog device control
- 6 high-speed inputs (X0–X5) suitable for rapid signal acquisition or AB encoders
- Compatible with Mitsubishi GX-Developer and GX-WORK2 software

### **Applications**

- Industrial automation systems
- Equipment control panels
- Systems requiring digital and analog signal processing
- Applications with time-based control using RTC
- Suitable for industrial environments and equipment

**Software: GX-Developer/GX Works2**

**Programming Cable : USB to Serial cable**

## Specifications:

Input Power	DC24
Number of steps	8000 steps; 2 communication ports: 1 RS232 (DB9 serial port iscommunication port for the FX3u protocol 38400,7, E, 1 ; 1 RS485 (485 selection) communication protocol can be set D8120).
X input element	DC24, X0-X27 input, Low-level X0-5 is a high-speed count input port ( <b>IK</b> )
Y output element	Y0-Y27 for optimal relay or transistor output, relay output current 5A.
Analog input	6 analog input, 12 bit precision, A0-AD2: 0-10V, A3-AD5 :0-20MA; read analog RD3A instruction.
Analog output	2 analog output, 12-bit precision, output voltage: 0-10V. output analog voltage with WR3A instruction
Intermediate relay M	M0-M3071, the scope of power loss saving can be set up. Rang M0-M1023
Stepper Point S	S0-1023, power down save range can be set up S0-S1023, Default is S500-S999
100Ms Timer	T0-T199, cumulative power down save T184-T199
10Ms Timer	T200-T249, cumulative power down save T246-T249
1Ms Timer	T250-T383 and T250-255 are the cumulative types
16-bit counter	C0-C199, power down save C100-199
32-bit counter	C200-C219, power down save C220-C234
32-bit high-speed counter	C235-255; C235-240 for the single-phase counter, Nonharmonic; C241-240 single-phase counter, frequency doubling;C247-249 Dual-phase counter, Non harmonic; C250-252 for the two-phase counter, frequency doubling; C253-255 biphasic counter, 4 frequency doubling;
Register D	D0-D7999, power-down save range can be set to D0-7999
Indirect addressing pointer V, Z	V0-7, Z0-7
P subroutine jump number	P0-63
I interrupt	X0-5 external interrupt. Timer interrupt (1MS unit). Timer interrupt.
Special element M	M8000 running normally closed,M8002 power pulse,M8011 is 10Ms pulse,M8012 is 100Ms pulse,M8013 is 1s pulse,M8014 minutes pulse.

**FX3U-48MR**  
**WIRING DIAGRAM**

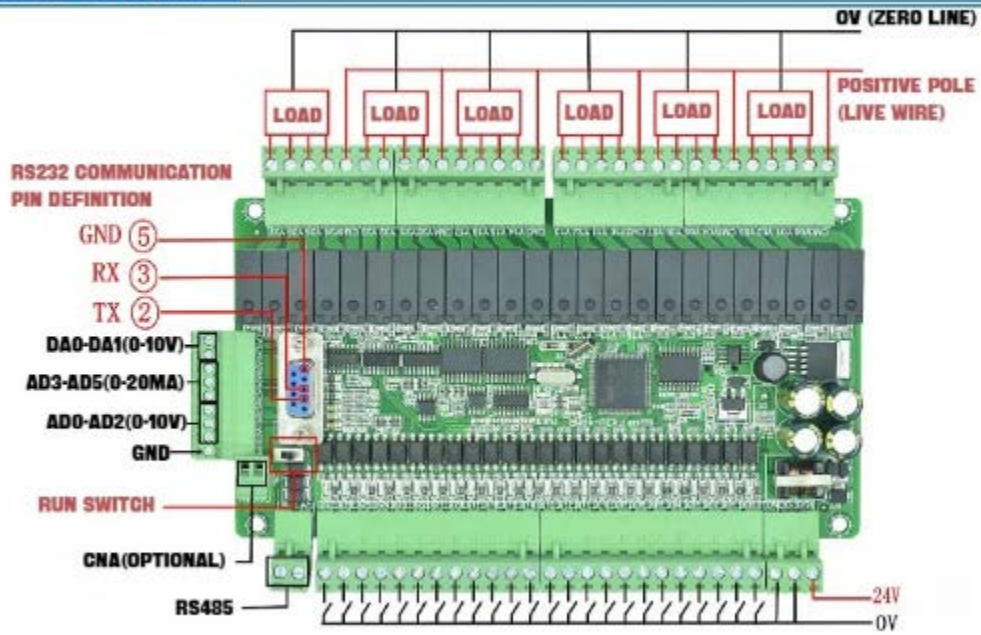

Note: X point input is negative. Low level NPN

Usb to Serial programming cable

